

**NZ 94/07 NEW ZEALAND – North Island – West Coast – North Taranaki Bight, Cape Egmont and South Taranaki Bight – Precautionary Area.**

**Chart NZ 21 (INT 641) [ 26/07 ]**

Insert	- - - - joining	38° 31'.0S., 174° 37'.8E. (MHWS) 39° 18'.5S., 173° 05'.0E. 39° 26'.0S., 173° 01'.0E. (chart edge)
	legend <i>Precautionary Area</i> (see Note) (aligned 57°)	39° 14'.8S., 173° 14'.8E.
	accompanying note	right of chart title

**Chart NZ 23 (INT 640) [ 26/07 ]**

Insert	- - - - joining	38° 31'.0S., 174° 37'.8E. (MHWS) 39° 18'.5S., 173° 05'.0E. 39° 26'.0S., 173° 01'.0E. 40° 03'.0S., 173° 04'.0E. 40° 10'.0S., 173° 16'.0E. 39° 53'.5S., 174° 54'.5E. (MHWS)
	legend <i>Precautionary Area</i> (see Note) (aligned 57°)	39° 11'.6S., 173° 22'.1E.
	legend <i>Precautionary Area</i> (see Note) (aligned 78°)	40° 06'.5S., 173° 31'.9E.
	accompanying note	left of chart title

**Chart NZ 25 (INT 648) [ 26/07 ]**

Insert	- - - - joining	38° 36'.0S., 174° 27'.5E. (chart edge) 39° 18'.5S., 173° 05'.0E. 39° 26'.0S., 173° 01'.0E. 40° 03'.0S., 173° 04'.0E. 40° 10'.0S., 173° 16'.0E. 39° 53'.5S., 174° 54'.5E. (MHWS)
	legend <i>Precautionary Area</i> (see Note) (aligned 57°)	39° 11'.6S., 173° 22'.1E.
	legend <i>Precautionary Area</i> (see Note) (aligned 78°)	40° 06'.5S., 173° 31'.9E.
	accompanying note	below chart title

(continued)

(continued)

**Chart NZ 43 [ 69/07 ]**

Insert	- - - - joining	38° 31'.0S., 174° 37'.8E. (MHWS) 39° 18'.5S., 173° 05'.0E. 39° 19'.9S., 173° 04'.2E. (chart edge)
	legend <i>Precautionary Area</i> (see Note) (aligned 57°)	39° 11'.7S., 173° 19'.3E.
	accompanying note	below chart title

**Chart NZ 45 [ 26/07 ]**

Insert	- - - - joining	39° 12'.4S., 173° 16'.8E. (chart edge) 39° 18'.5S., 173° 05'.0E. 39° 26'.0S., 173° 01'.0E. 40° 03'.0S., 173° 04'.0E. 40° 10'.0S., 173° 16'.0E. 39° 53'.5S., 174° 54'.5E. (MHWS)
	legend <i>Precautionary Area</i> (see Note) (aligned 57°)	39° 16'.2S., 173° 10'.5E.
	legend <i>Precautionary Area</i> (see Note) (aligned 176°)	39° 46'.8S., 173° 03'.1E.
	legend <i>Precautionary Area</i> (see Note) (aligned 78°)	40° 07'.4S., 173° 29'.7E.
	accompanying note	below chart title

**Chart NZ 48 [ 53/07 ]**

Insert	- - - - joining	38° 56'.0S., 173° 48'.8E. (chart edge) 39° 18'.5S., 173° 05'.0E. 39° 26'.0S., 173° 01'.0E. 40° 03'.0S., 173° 04'.0E. 40° 10'.0S., 173° 16'.0E. 39° 53'.5S., 174° 54'.5E. (MHWS)
	legend <i>Precautionary Area</i> (see Note) (aligned 57°)	39° 10'.7S., 173° 22'.0E.
	legend <i>Precautionary Area</i> (see Note) (aligned 78°)	40° 05'.8S., 173° 39'.3E.
	accompanying note	below chart title

(continued)

(continued)

**Chart NZ 443 [ 26/07 ]**

Insert	----- joining	38° 39'.6S., 174° 21'.0E. (chart edge)
		39° 13'.4S., 173° 15'.0E. (chart edge)
	legend <i>Precautionary Area</i> (see Note) (aligned 57°)	39° 11'.3S., 173° 20'.1E. 38° 46'.0S., 174° 09'.6E.
	accompanying note	below chart title

**Chart NZ 4432 [ 143/03 ]**

Insert	legend <i>Precautionary Area</i> (see Note)	39° 00'.33S., 173° 59'.33E. 38° 58'.51S., 174° 07'.00E.
	accompanying note	left of chart title

International Maritime Organization  
 NI 96/2007

**RIGHT BELOW CENTRE**

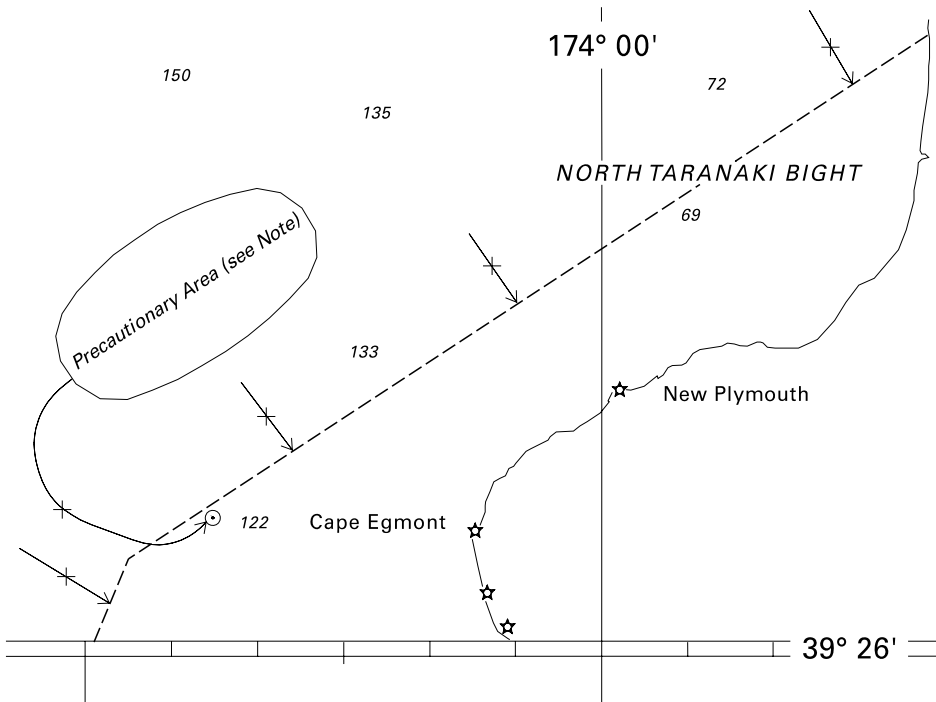

<i>Issued as a guide to chart correction.</i>		<i>Use in conjunction with the appropriate NZ Notice to Mariners.</i>	
<b>LAST CORRECTION</b>	<b>NZ NTM No.</b>	<b>CHART No.</b>	
<b>NZ 26/07</b>	<b>NZ 94/07</b>	<b>NZ 21 (INT 641)</b>	

**RIGHT BELOW CENTRE  
 RIGHT OF TITLE**

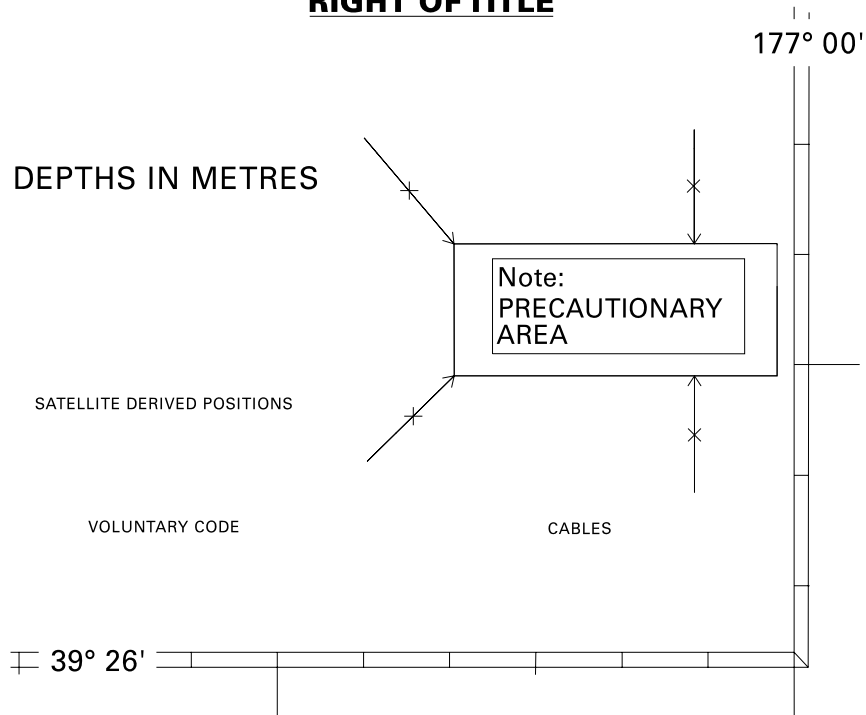

<i>Issued as a guide to chart correction.</i>		<i>Use in conjunction with the appropriate NZ Notice to Mariners.</i>	
<b>LAST CORRECTION</b>	<b>NZ NTM No.</b>	<b>CHART No.</b>	
<b>NZ 26/07</b>	<b>NZ 94/07</b>	<b>NZ 21 (INT 641)</b>	

**RIGHT BELOW CENTRE  
 LEFT OF TITLE**

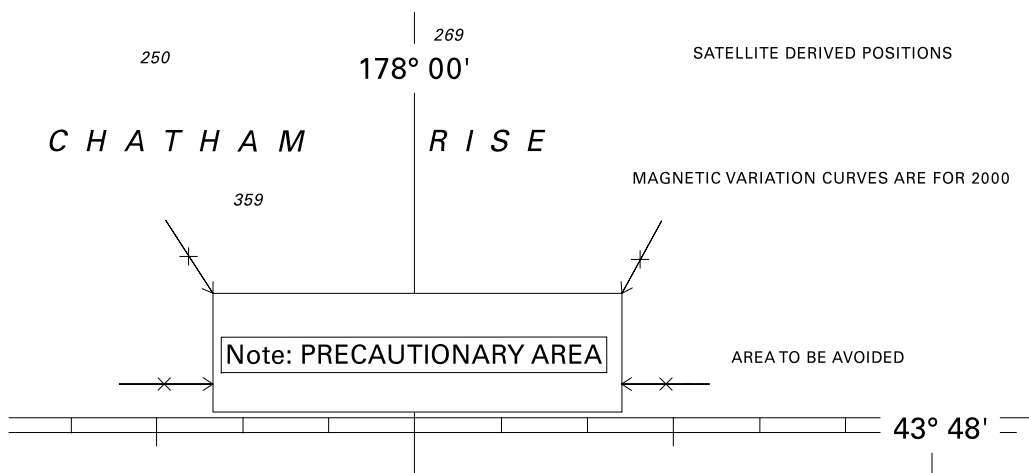

<i>Issued as a guide to chart correction.</i>		<i>Use in conjunction with the appropriate NZ Notice to Mariners.</i>	
<b>LAST CORRECTION</b>	<b>NZ NTM No.</b>	<b>CHART No.</b>	
<b>NZ 26/07</b>	<b>NZ 94/07</b>	<b>NZ 23 (INT 640)</b>	

**LEFT BELOW CENTRE**

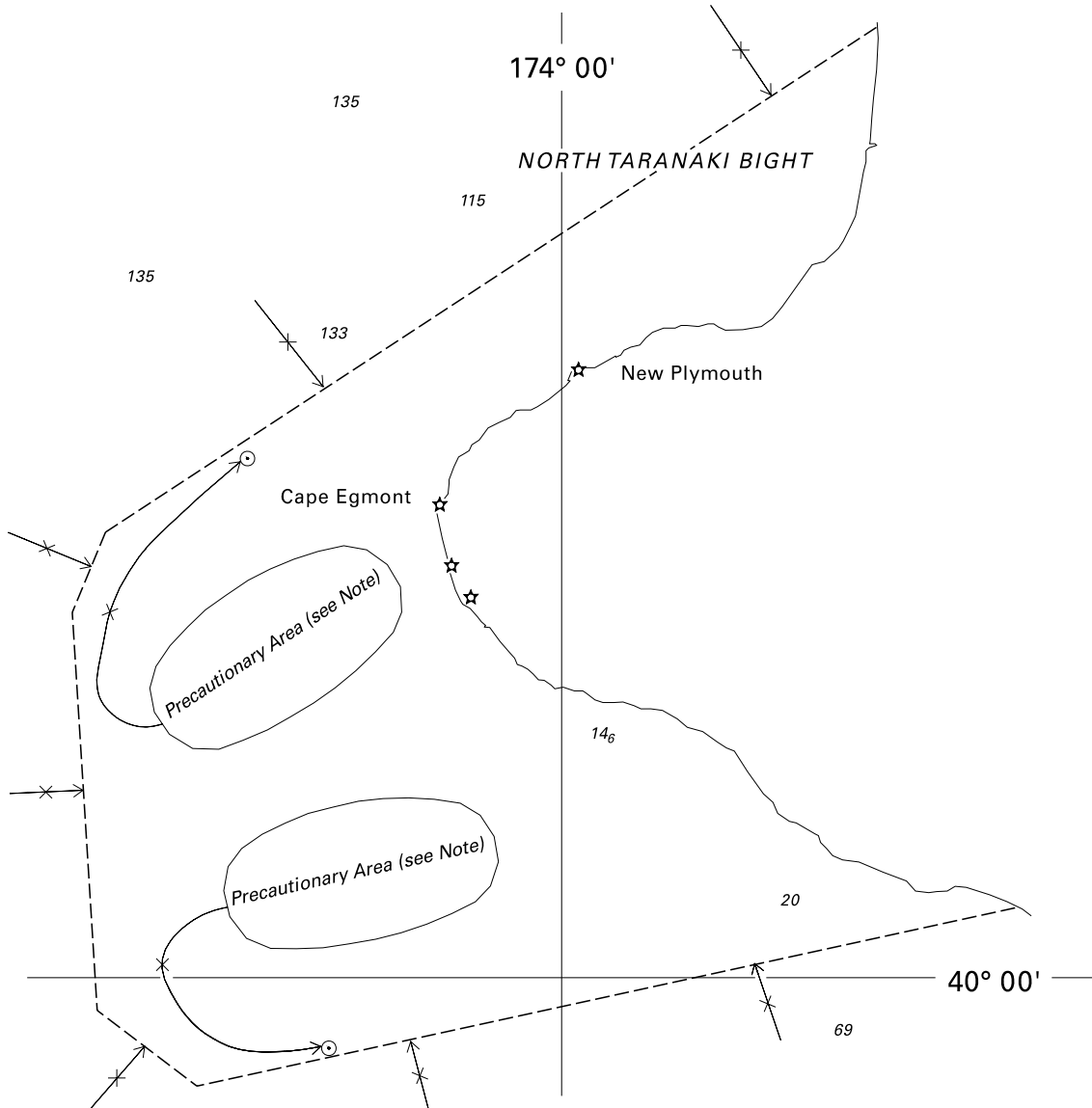

<i>Issued as a guide to chart correction.</i>		<i>Use in conjunction with the appropriate NZ Notice to Mariners.</i>	
<b>LAST CORRECTION</b>	<b>NZ NTM No.</b>	<b>CHART No.</b>	
<b>NZ 26/07</b>	<b>NZ 94/07</b>	<b>NZ 23 (INT 640)</b>	

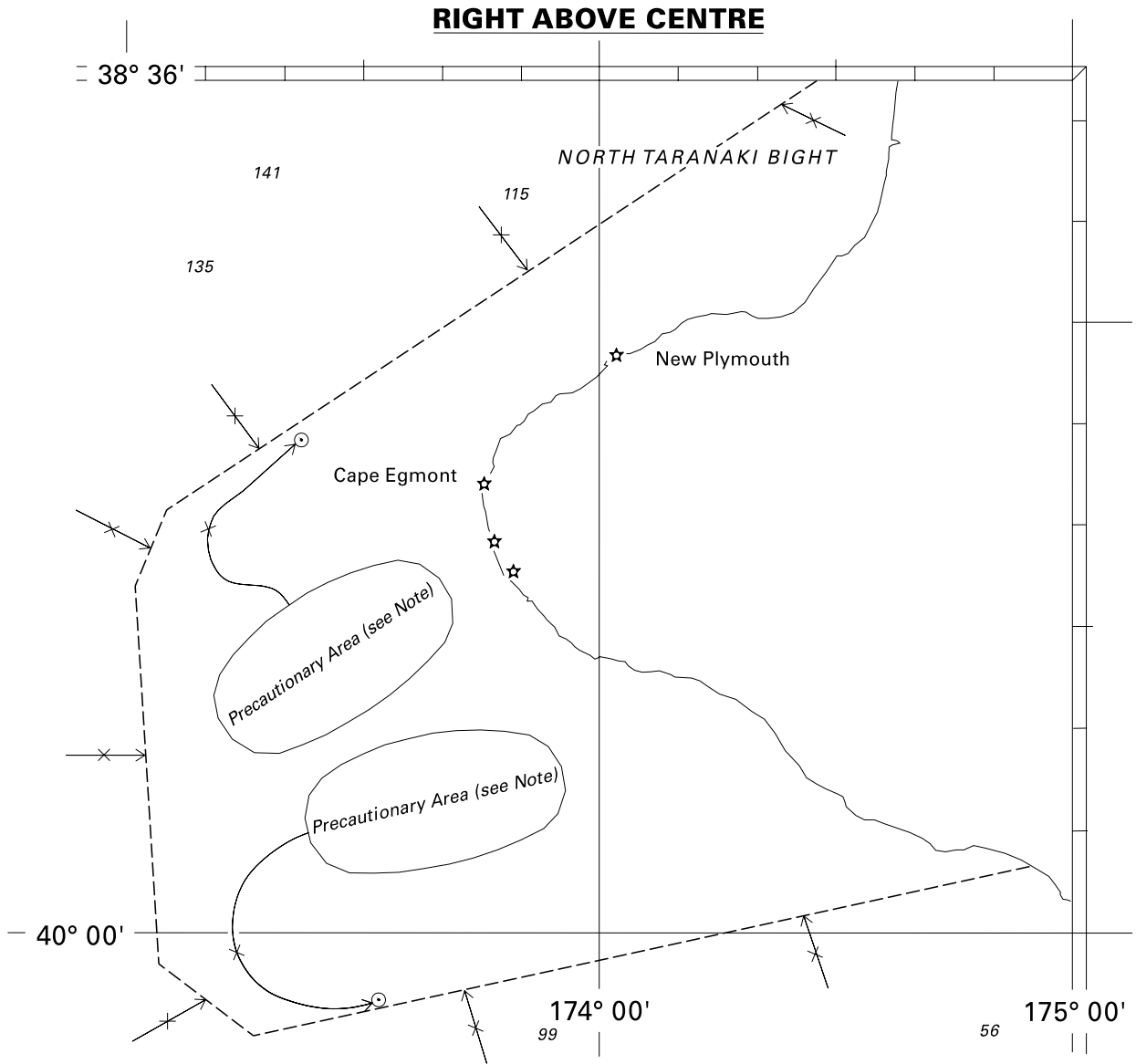

<i>Issued as a guide to chart correction.</i>		<i>Use in conjunction with the appropriate NZ Notice to Mariners.</i>	
<b>LAST CORRECTION</b>	<b>NZ NTM No.</b>	<b>CHART No.</b>	
<b>NZ 26/07</b>	<b>NZ 94/07</b>	<b>NZ 25 (INT 648)</b>	

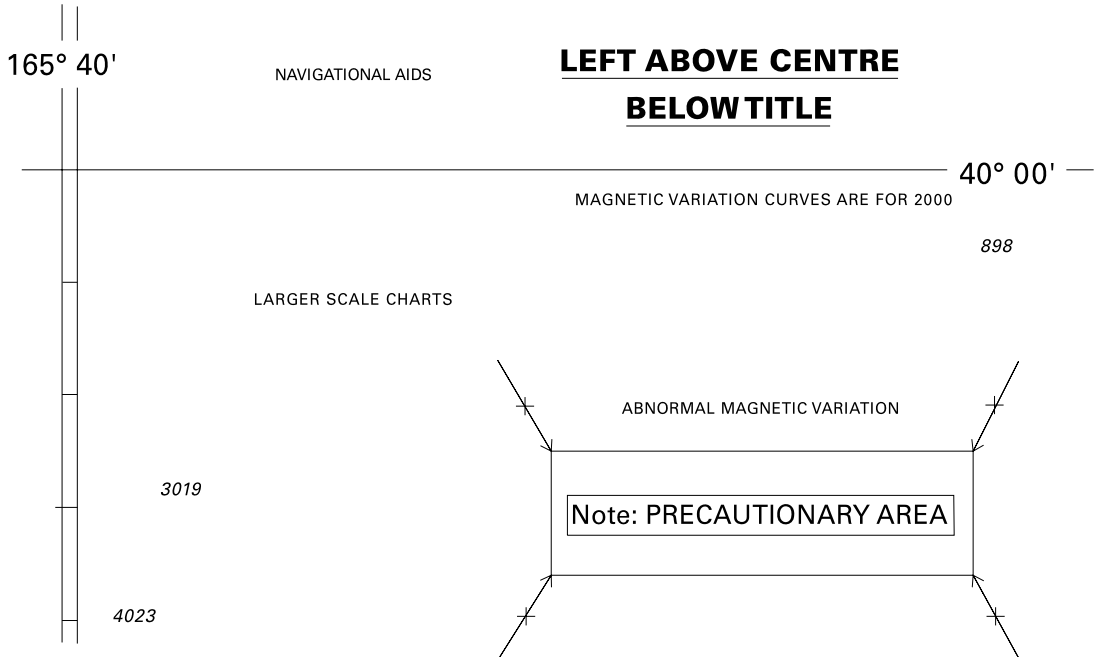

<i>Issued as a guide to chart correction.</i>		<i>Use in conjunction with the appropriate NZ Notice to Mariners.</i>
<b>LAST CORRECTION</b>	<b>NZ NTM No.</b>	<b>CHART No.</b>
<b>NZ 26/07</b>	<b>NZ 94/07</b>	<b>NZ 25 (INT 648)</b>

**LEFT ABOVE CENTRE**  
**BELOW TITLE**

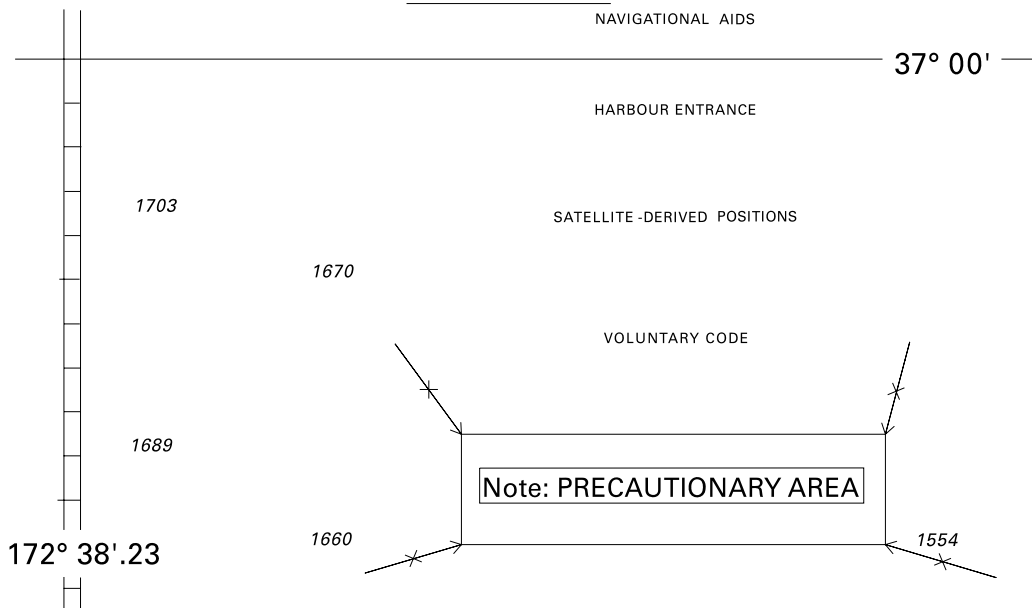

<i>Issued as a guide to chart correction.</i>		<i>Use in conjunction with the appropriate NZ Notice to Mariners.</i>
<b>LAST CORRECTION</b>	<b>NZ NTM No.</b>	<b>CHART No.</b>
<b>NZ 69/07</b>	<b>NZ 94/07</b>	<b>NZ 43</b>

**LEFT BELOW CENTRE**

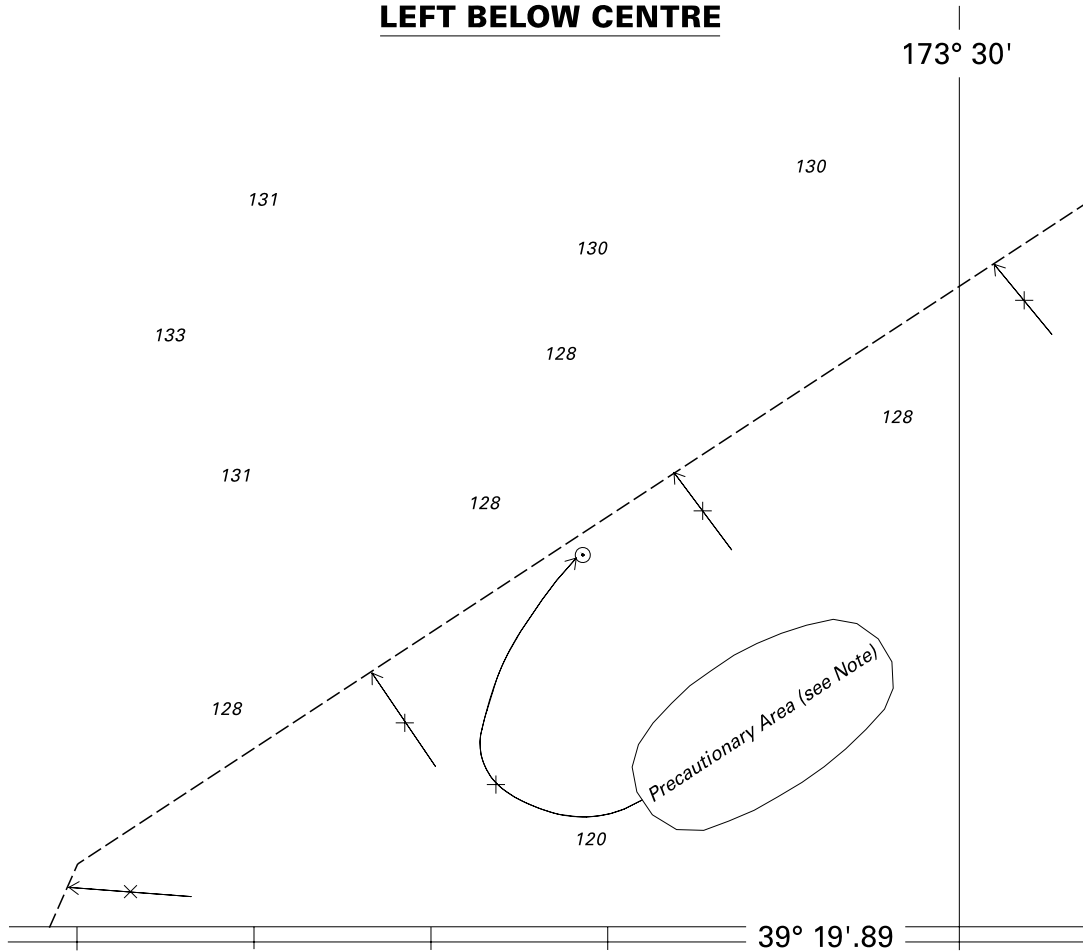

<i>Issued as a guide to chart correction.</i>		<i>Use in conjunction with the appropriate NZ Notice to Mariners.</i>	
<b>LAST CORRECTION</b>	<b>NZ NTM No.</b>	<b>CHART No.</b>	
<b>NZ 69/07</b>	<b>NZ 94/07</b>	<b>NZ 43</b>	



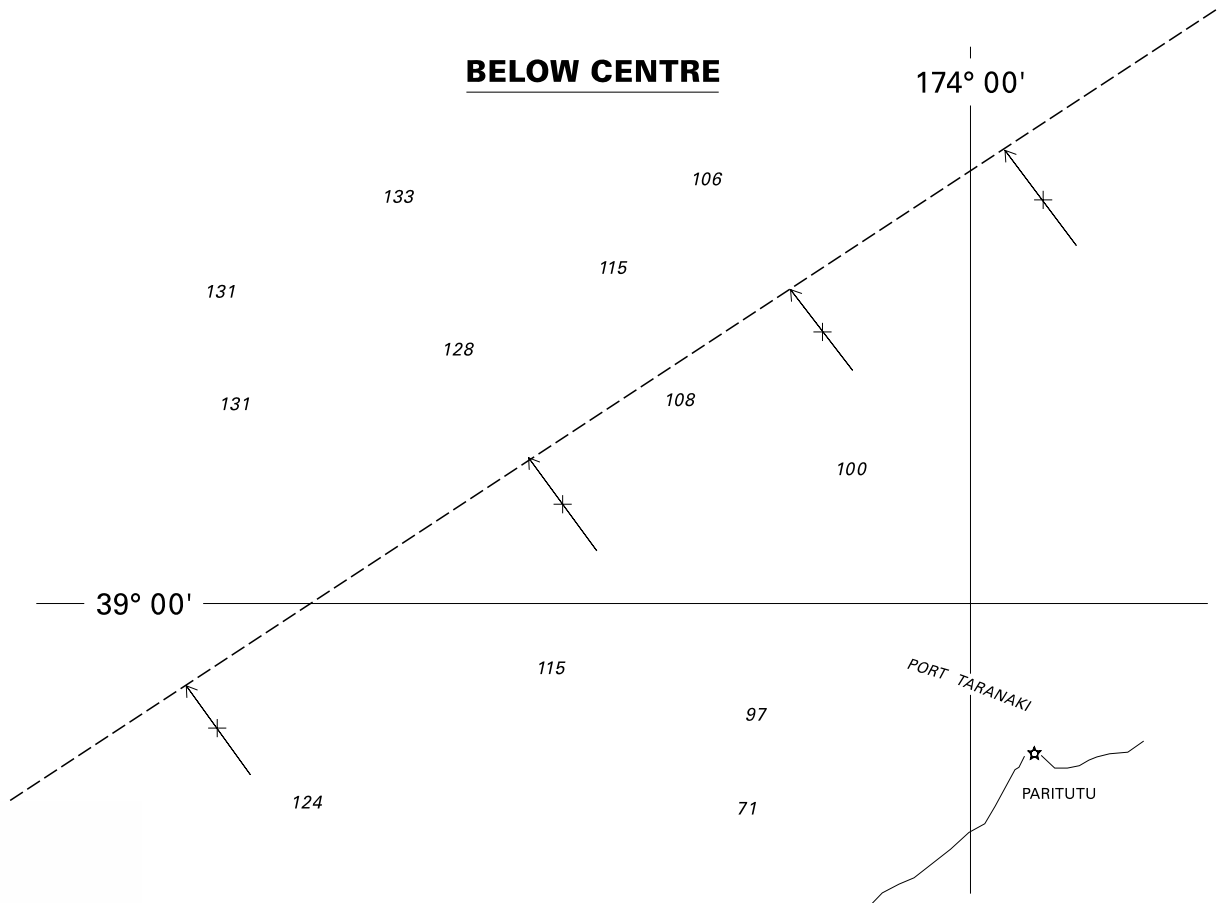

<i>Issued as a guide to chart correction.</i>		<i>Use in conjunction with the appropriate NZ Notice to Mariners.</i>	
<b>LAST CORRECTION</b>	<b>NZ NTM No.</b>	<b>CHART No.</b>	
<b>NZ 69/07</b>	<b>NZ 94/07</b>	<b>NZ 43</b>	

**RIGHT BELOW CENTRE**

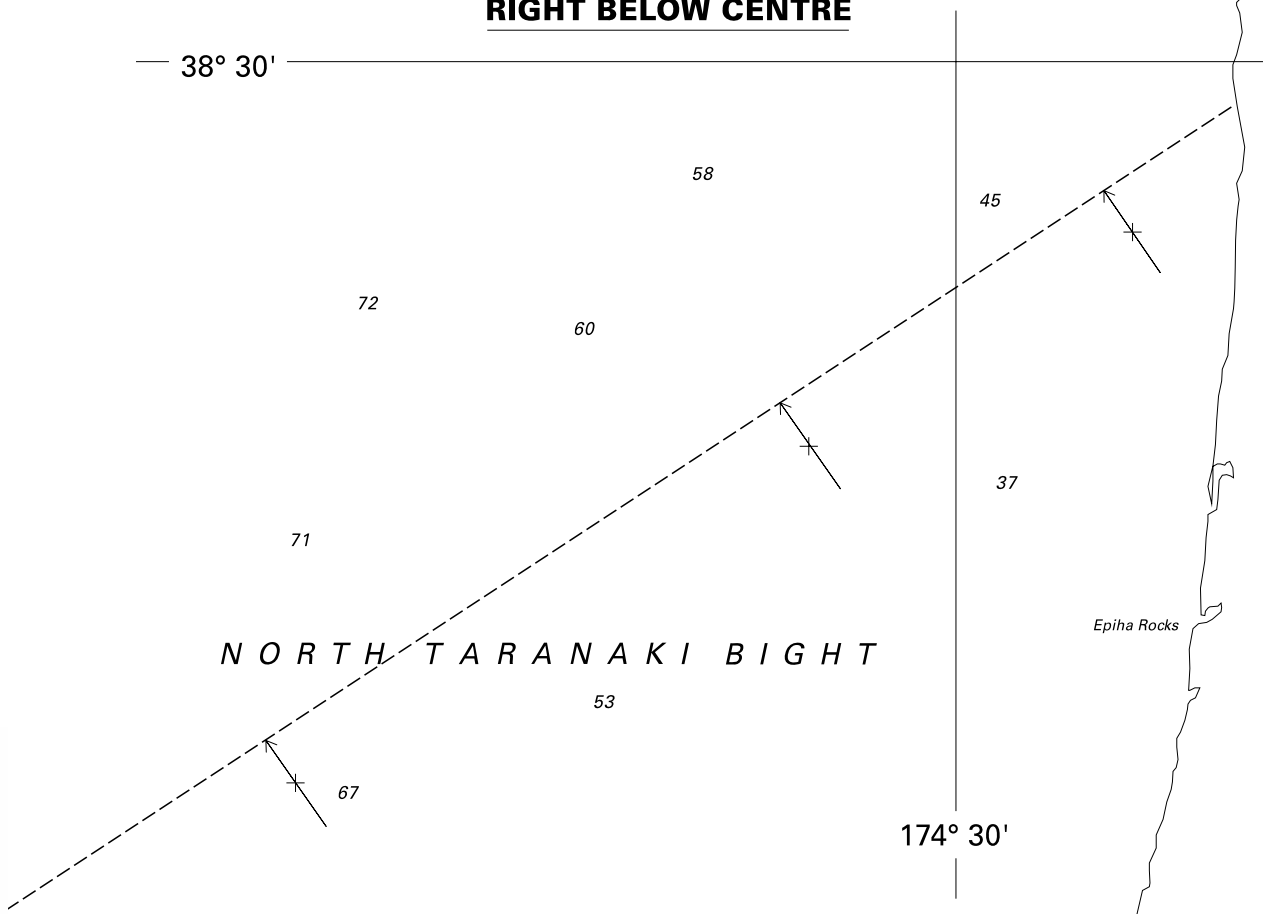

<i>Issued as a guide to chart correction.</i>		<i>Use in conjunction with the appropriate NZ Notice to Mariners.</i>	
<b>LAST CORRECTION</b>	<b>NZ NTM No.</b>	<b>CHART No.</b>	
<b>NZ 69/07</b>	<b>NZ 94/07</b>	<b>NZ 43</b>	

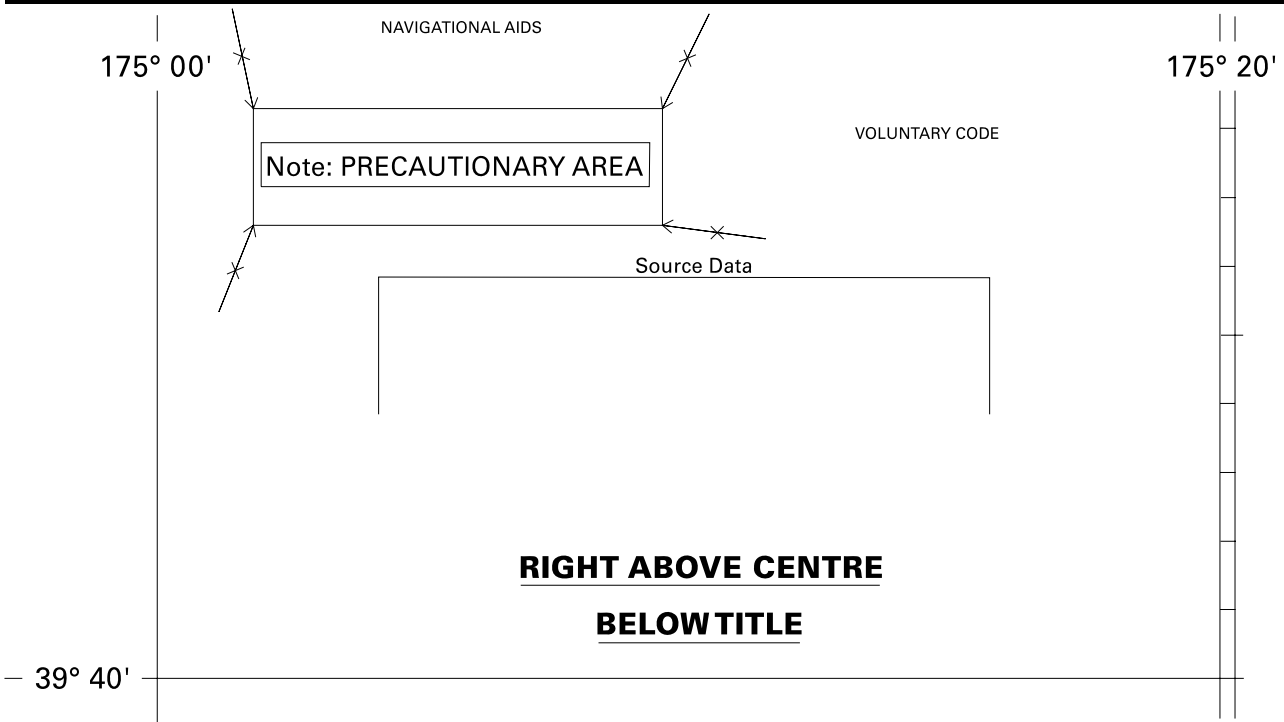

<i>Issued as a guide to chart correction.</i>		<i>Use in conjunction with the appropriate NZ Notice to Mariners.</i>	
<b>LAST CORRECTION</b>	<b>NZ NTM No.</b>	<b>CHART No.</b>	
<b>NZ 26/07</b>	<b>NZ 94/07</b>	<b>NZ 45</b>	

**RIGHT BELOW CENTRE**

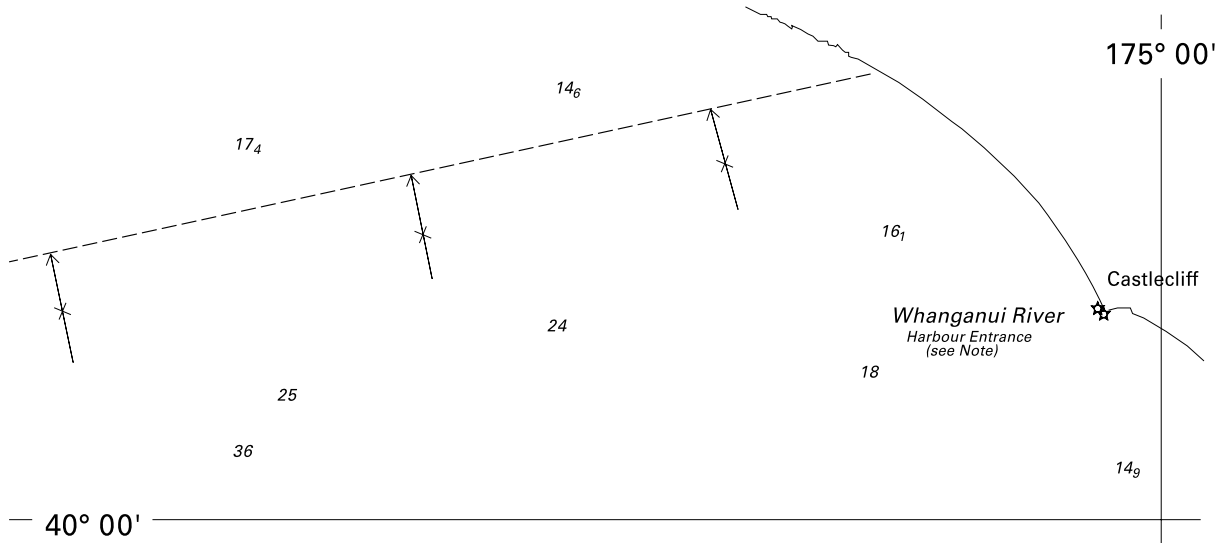

**RIGHT BELOW CENTRE**

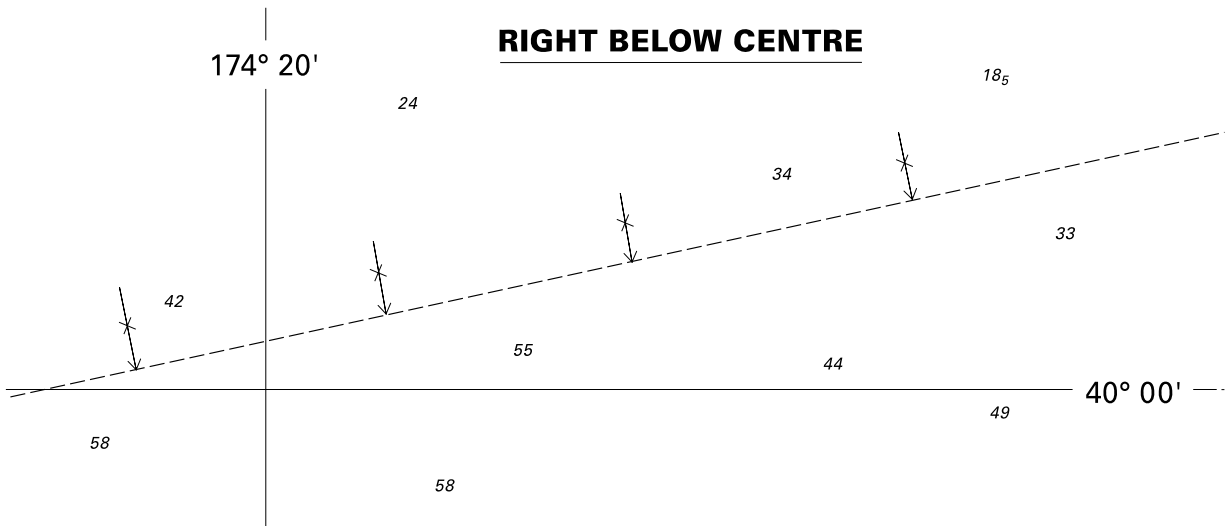

**BELOW CENTRE**

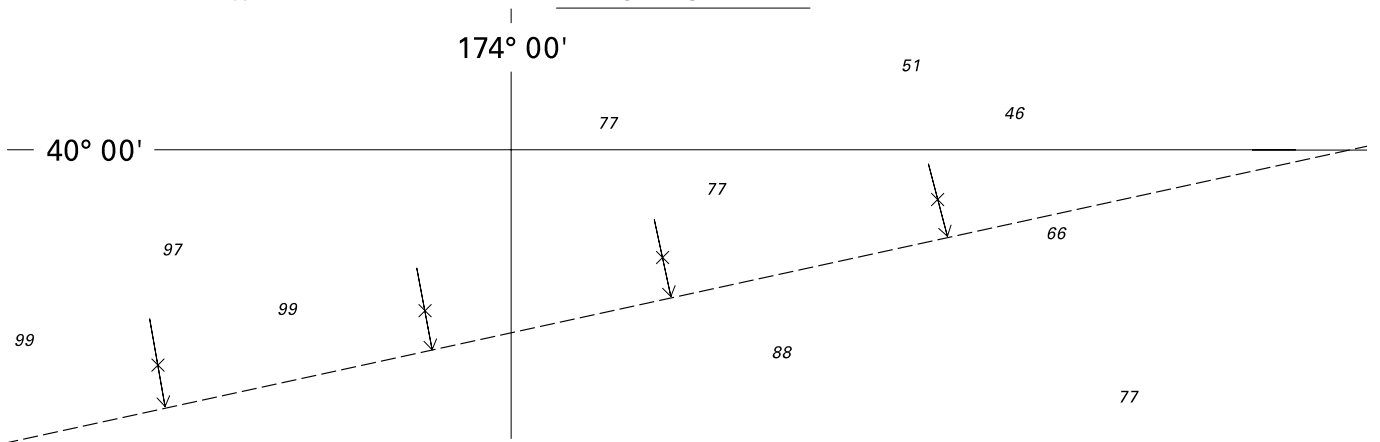

<i>Issued as a guide to chart correction.</i>		<i>Use in conjunction with the appropriate NZ Notice to Mariners.</i>
<b>LAST CORRECTION</b>	<b>NZ NTM No.</b>	<b>CHART No.</b>
<b>NZ 26/07</b>	<b>NZ 94/07</b>	<b>NZ 45</b>

**LEFT BELOW CENTRE**

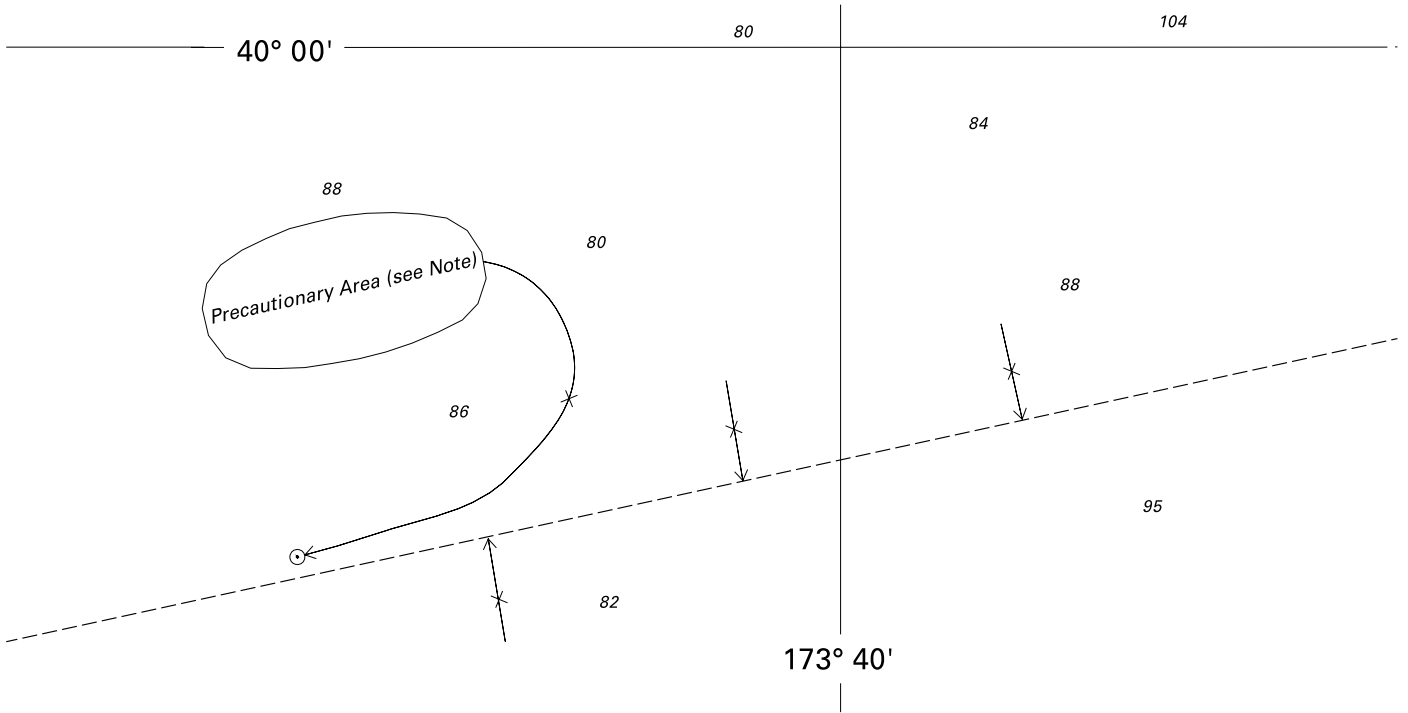

**LEFT BELOW CENTRE**

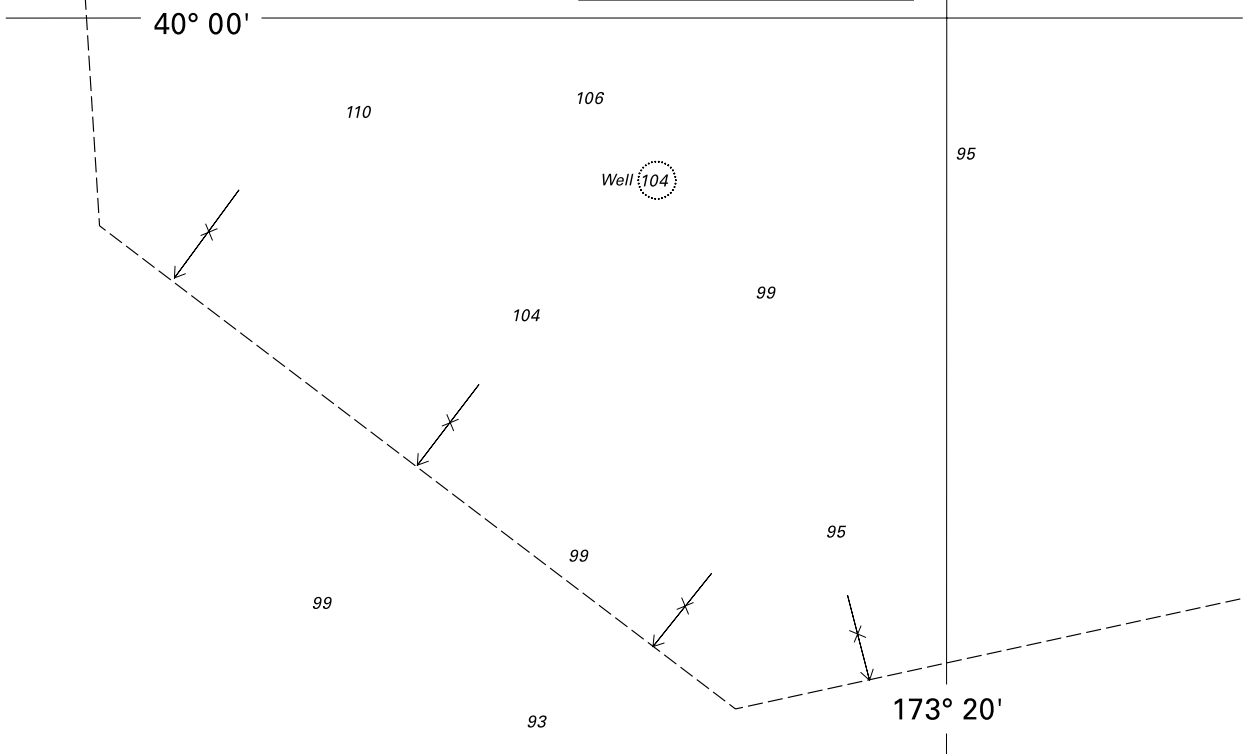

<i>Issued as a guide to chart correction.</i>		<i>Use in conjunction with the appropriate NZ Notice to Mariners.</i>
<b>LAST CORRECTION</b>	<b>NZ NTM No.</b>	<b>CHART No.</b>
<b>NZ 26/07</b>	<b>NZ 94/07</b>	<b>NZ 45</b>

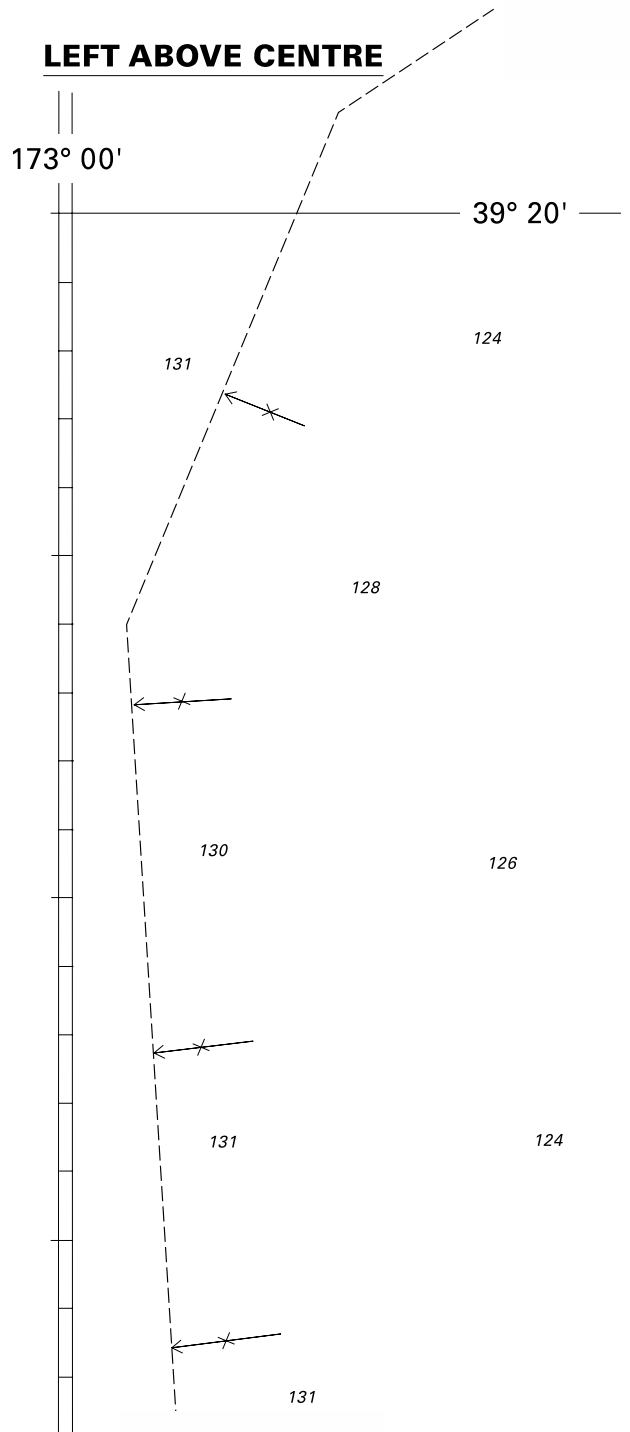
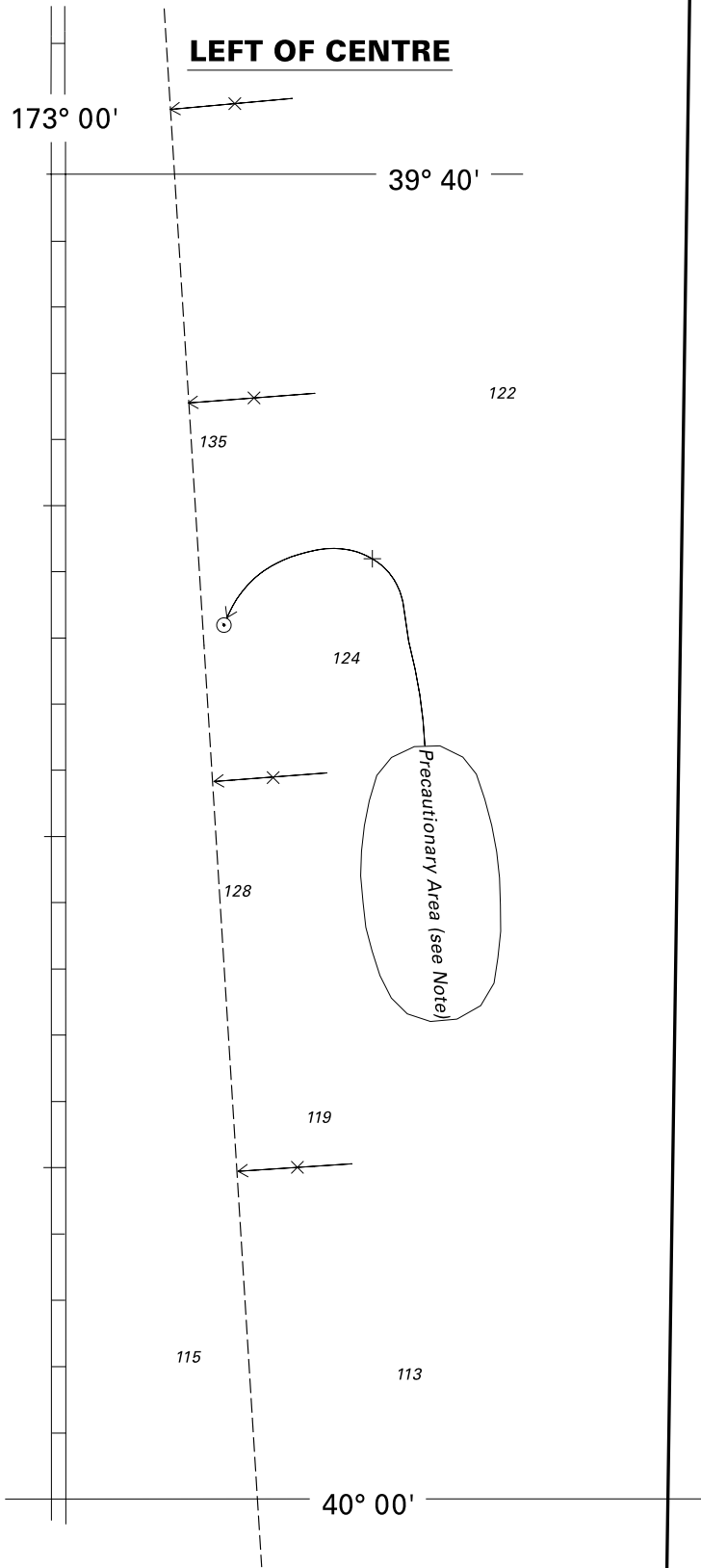

<i>Issued as a guide to chart correction.</i>		<i>Use in conjunction with the appropriate NZ Notice to Mariners.</i>	
<b>LAST CORRECTION</b>	<b>NZ NTM No.</b>	<b>CHART No.</b>	
<b>NZ 26/07</b>	<b>NZ 94/07</b>	<b>NZ 45</b>	

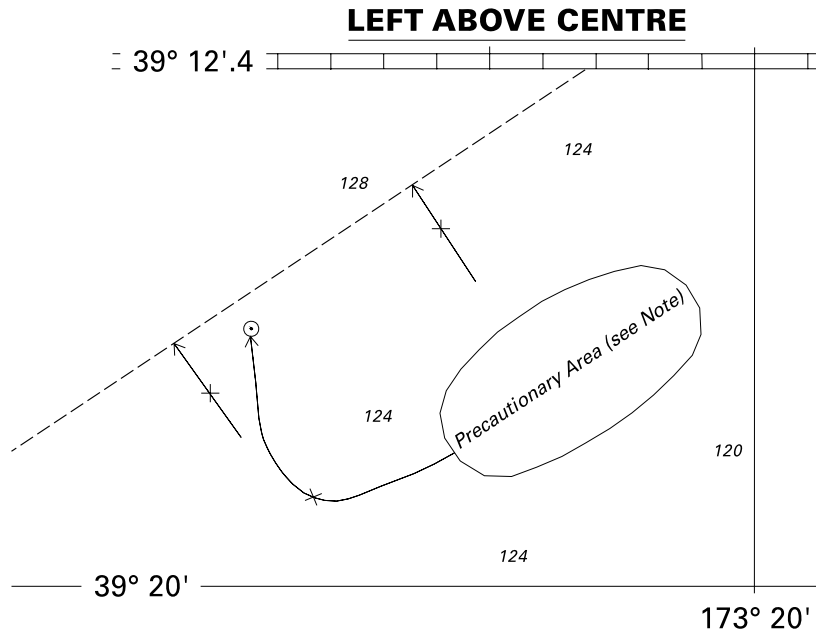

<i>Issued as a guide to chart correction.</i>		<i>Use in conjunction with the appropriate NZ Notice to Mariners.</i>	
<b>LAST CORRECTION</b>	<b>NZ NTM No.</b>	<b>CHART No.</b>	
<b>NZ 26/07</b>	<b>NZ 94/07</b>	<b>NZ 45</b>	

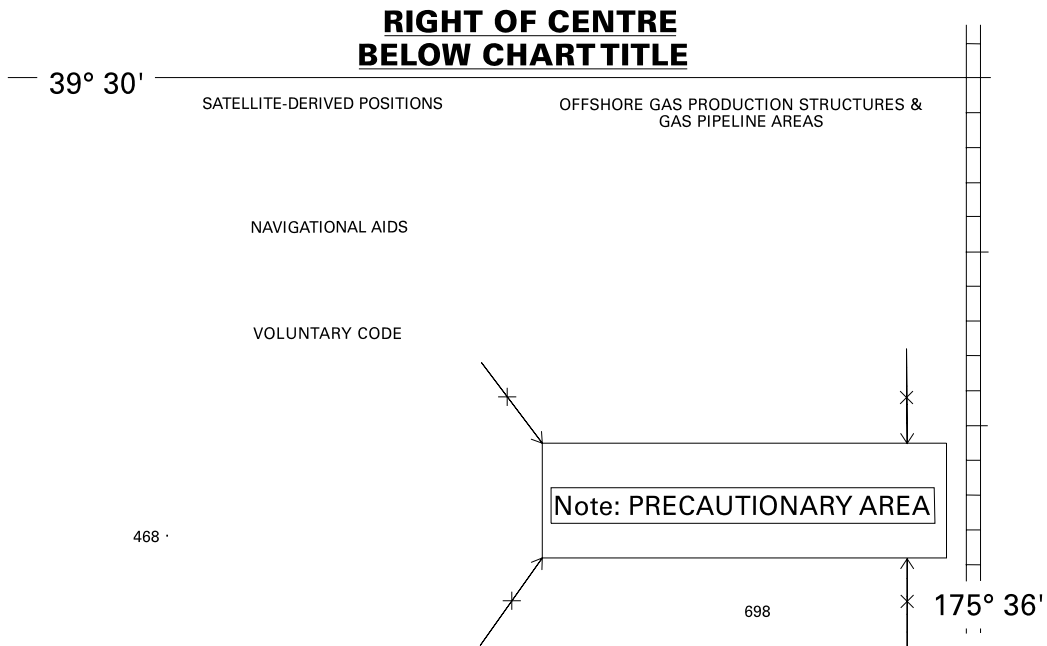

<i>Issued as a guide to chart correction.</i>		<i>Use in conjunction with the appropriate NZ Notice to Mariners.</i>	
<b>LAST CORRECTION</b>	<b>NZ NTM No.</b>	<b>CHART No.</b>	
<b>NZ 53/07</b>	<b>NZ 94/07</b>	<b>NZ 48</b>	

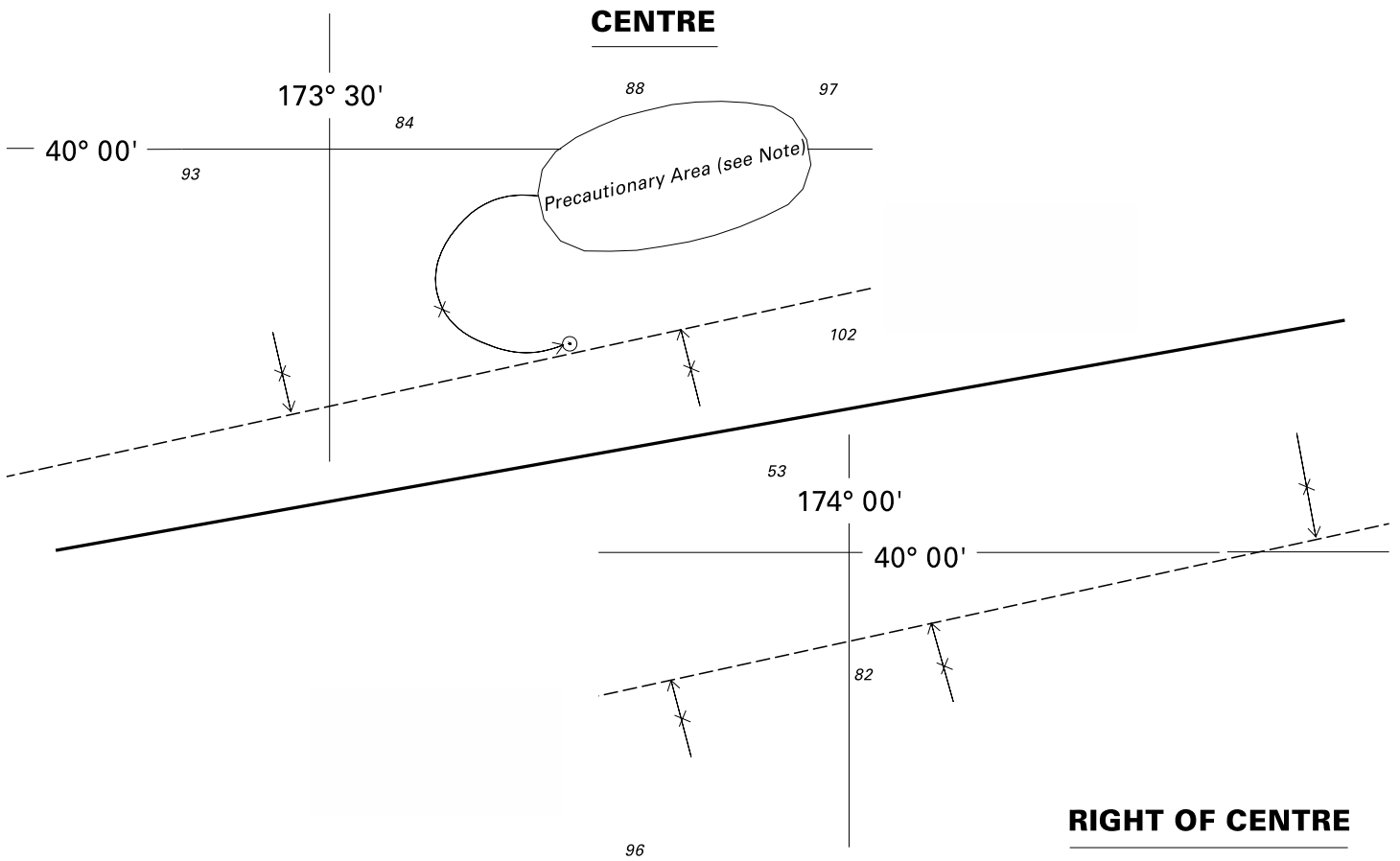
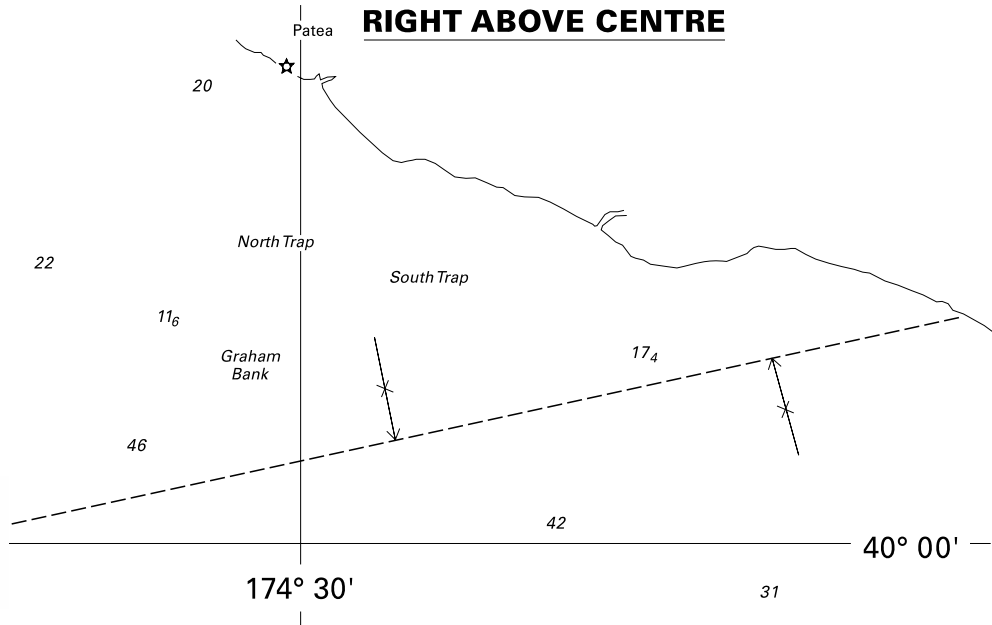

<i>Issued as a guide to chart correction.</i>		<i>Use in conjunction with the appropriate NZ Notice to Mariners.</i>	
<b>LAST CORRECTION</b>	<b>NZ NTM No.</b>	<b>CHART No.</b>	
<b>NZ 53/07</b>	<b>NZ 94/07</b>	<b>NZ 48</b>	

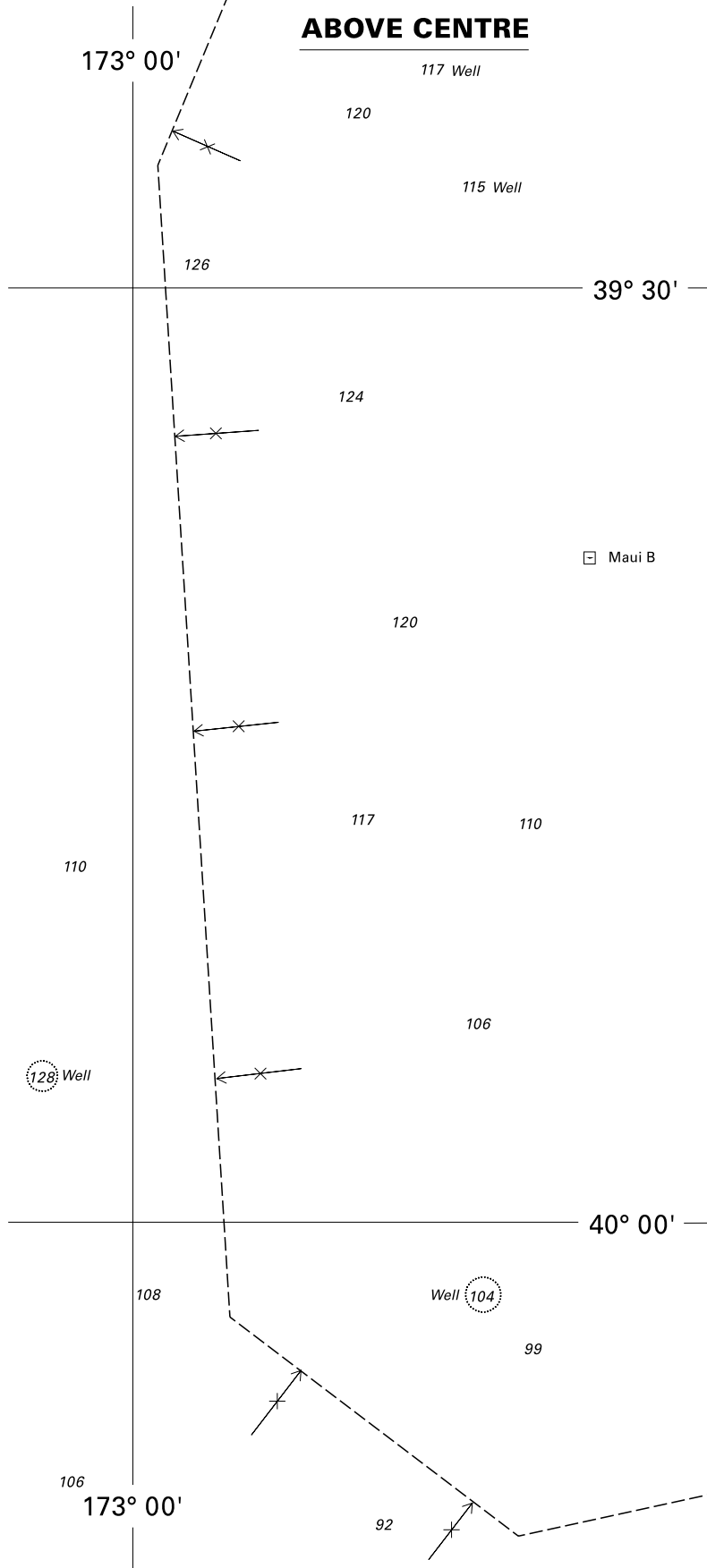

<i>Issued as a guide to chart correction.</i>		<i>Use in conjunction with the appropriate NZ Notice to Mariners.</i>	
<b>LAST CORRECTION</b>	<b>NZ NTM No.</b>	<b>CHART No.</b>	
<b>NZ 53/07</b>	<b>NZ 94/07</b>	<b>NZ 48</b>	



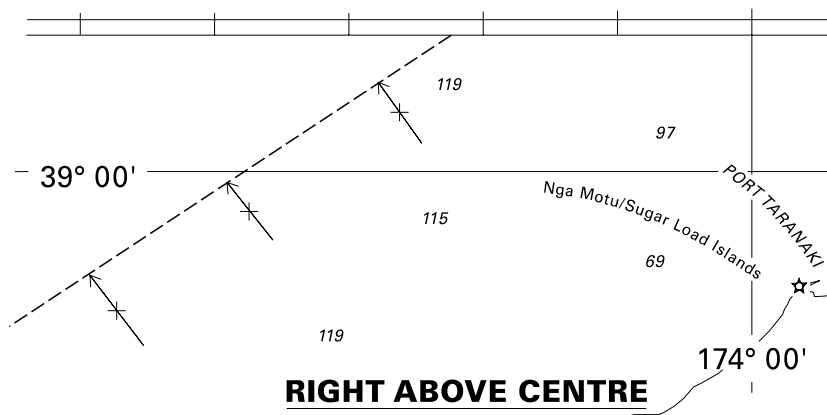
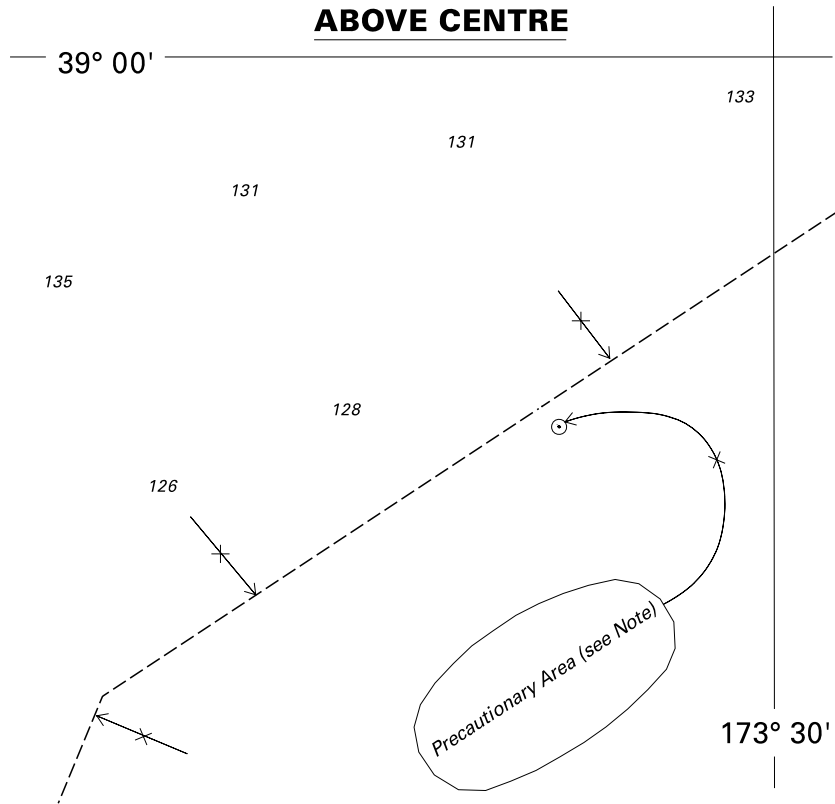

<i>Issued as a guide to chart correction.</i>		<i>Use in conjunction with the appropriate NZ Notice to Mariners.</i>	
<b>LAST CORRECTION</b>	<b>NZ NTM No.</b>	<b>CHART No.</b>	
<b>NZ 53/07</b>	<b>NZ 94/07</b>	<b>NZ 48</b>	

**RIGHT BELOW CENTRE  
 BELOW TITLE**

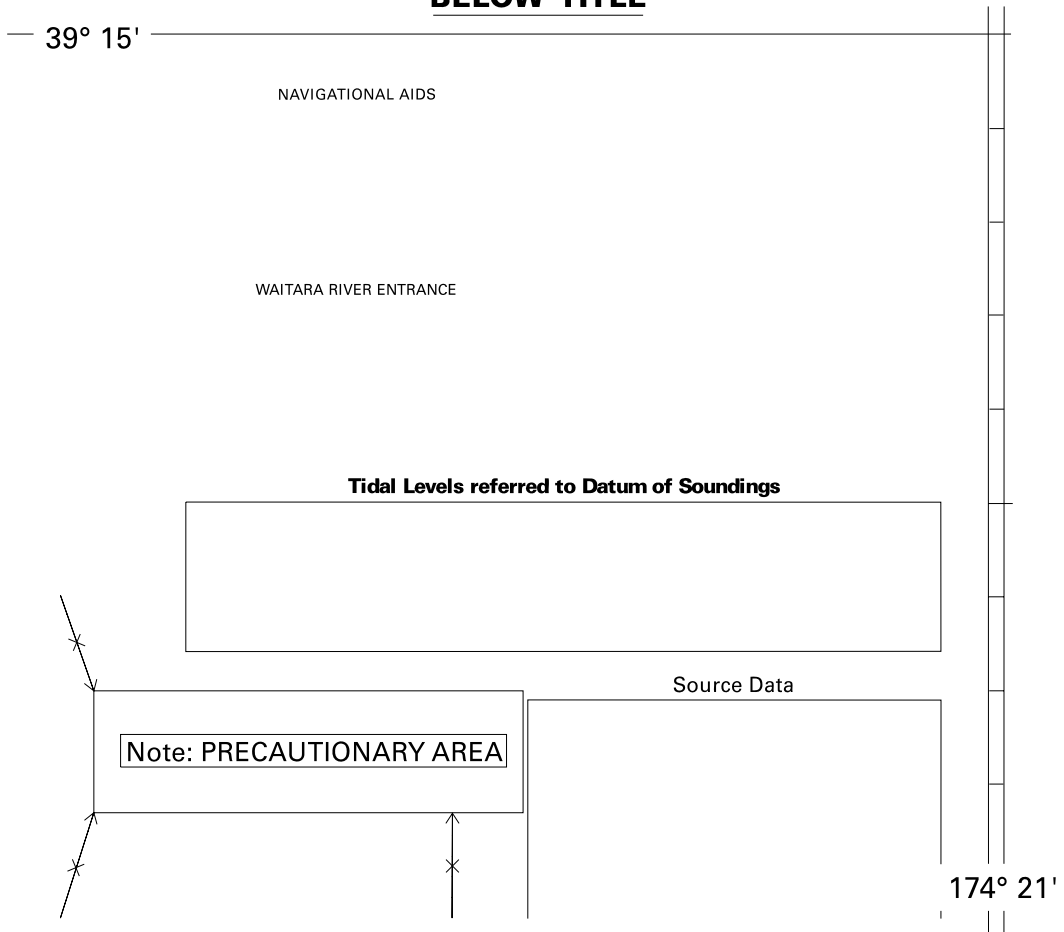

<i>Issued as a guide to chart correction.</i>		<i>Use in conjunction with the appropriate NZ Notice to Mariners.</i>	
<b>LAST CORRECTION</b>	<b>NZ NTM No.</b>	<b>CHART No.</b>	
<b>NZ 26/07</b>	<b>NZ 94/07</b>	<b>NZ 443</b>	

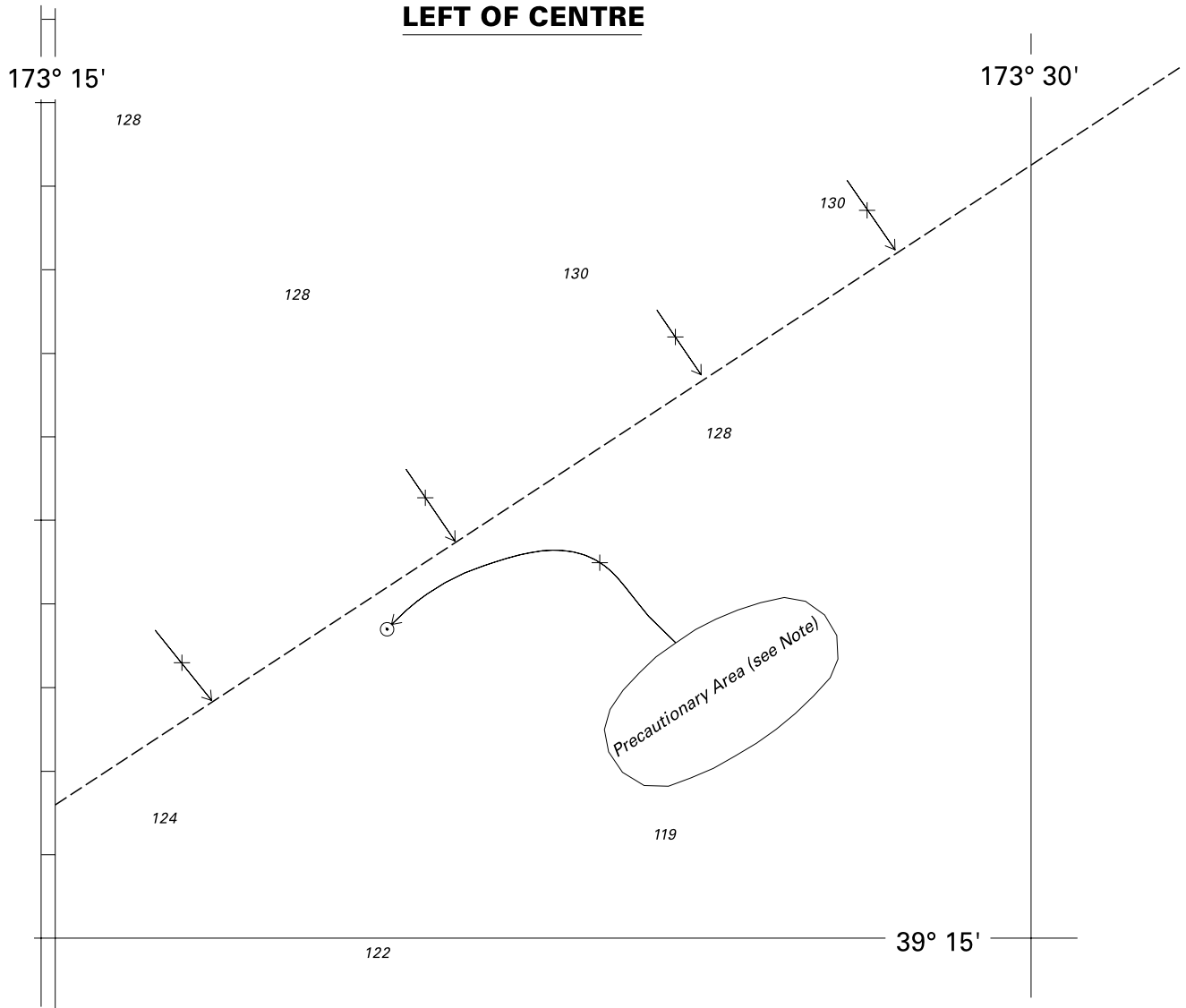

<i>Issued as a guide to chart correction.</i>		<i>Use in conjunction with the appropriate NZ Notice to Mariners.</i>	
<b>LAST CORRECTION</b>	<b>NZ NTM No.</b>	<b>CHART No.</b>	
<b>NZ 26/07</b>	<b>NZ 94/07</b>	<b>NZ 443</b>	

**LEFT ABOVE CENTRE**

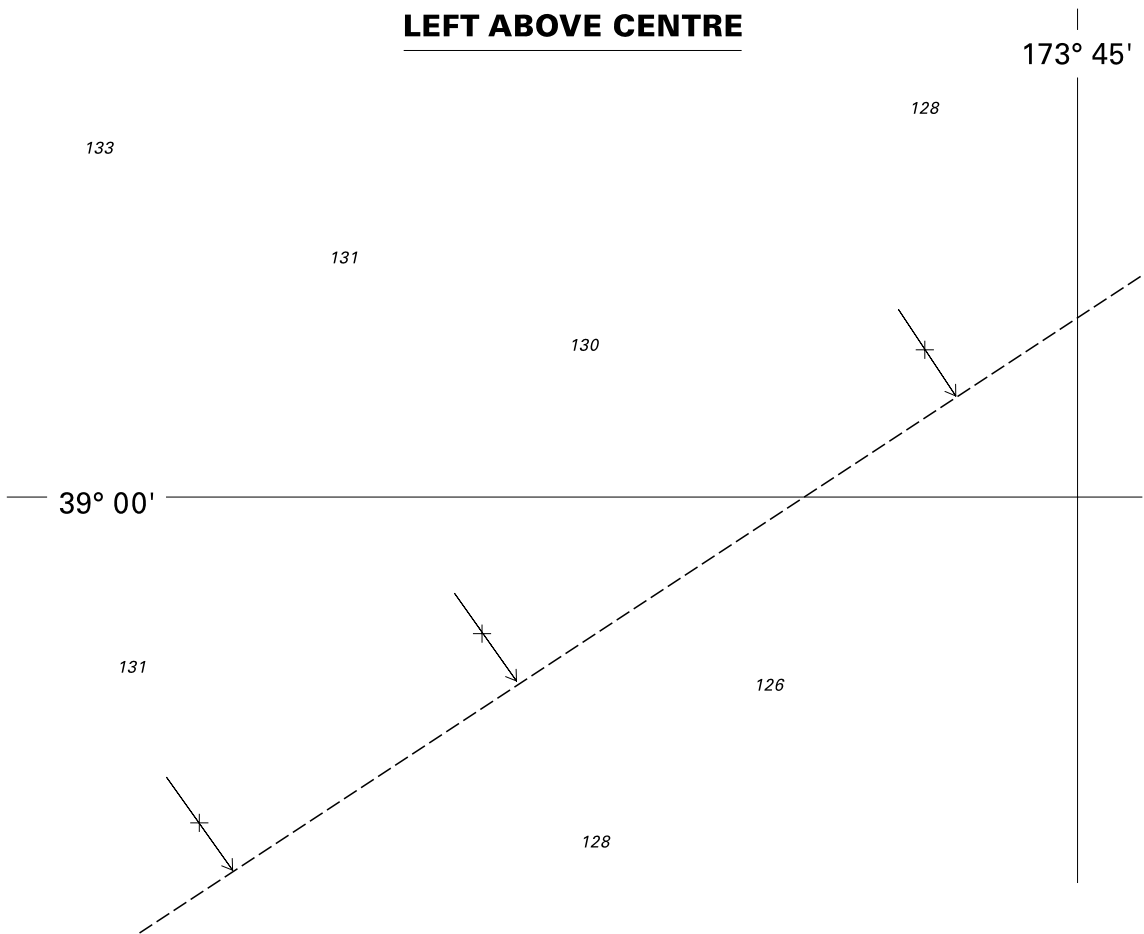

**RIGHT ABOVE CENTRE**

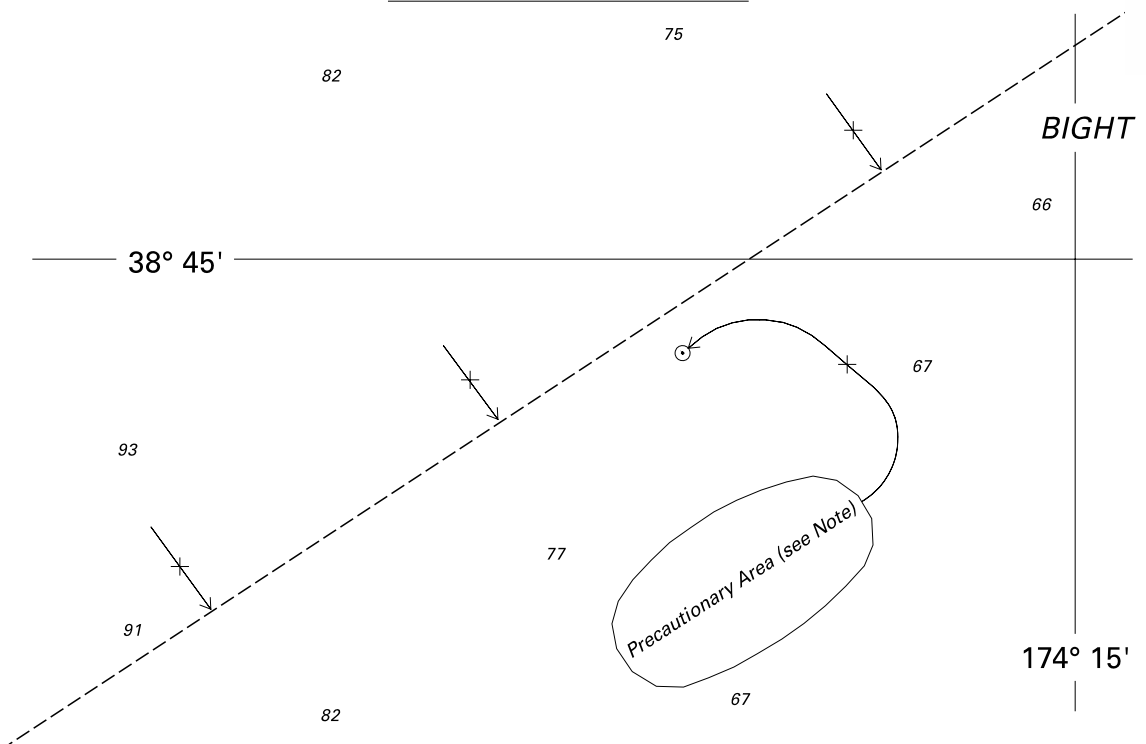

<i>Issued as a guide to chart correction.</i>		<i>Use in conjunction with the appropriate NZ Notice to Mariners.</i>
<b>LAST CORRECTION</b>	<b>NZ NTM No.</b>	<b>CHART No.</b>
<b>NZ 26/07</b>	<b>NZ 94/07</b>	<b>NZ 443</b>

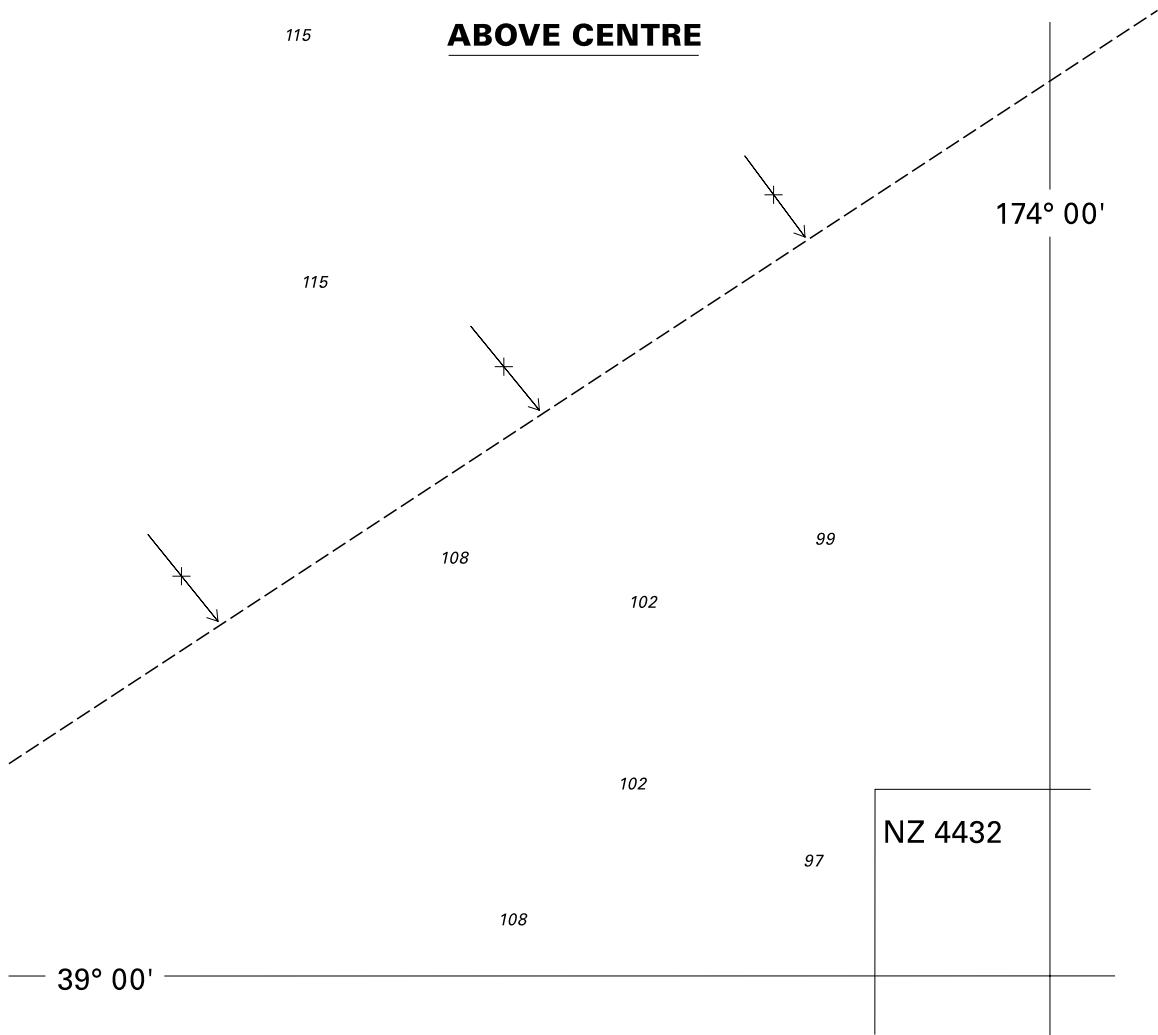

**RIGHT ABOVE CENTRE**

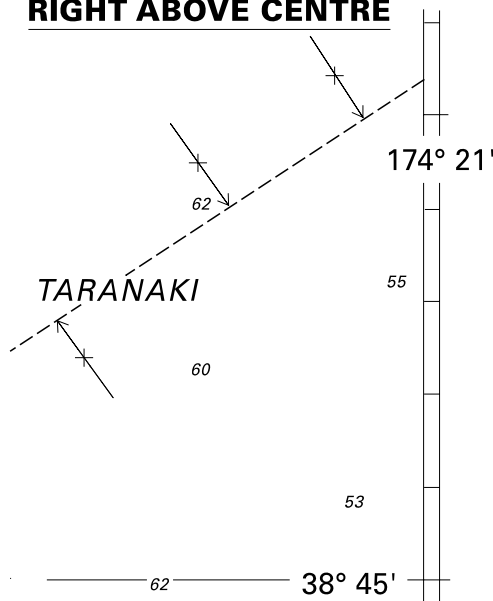

<i>Issued as a guide to chart correction.</i>		<i>Use in conjunction with the appropriate NZ Notice to Mariners.</i>	
<b>LAST CORRECTION</b>	<b>NZ NTM No.</b>	<b>CHART No.</b>	
<b>NZ 26/07</b>	<b>NZ 94/07</b>	<b>NZ 443</b>	

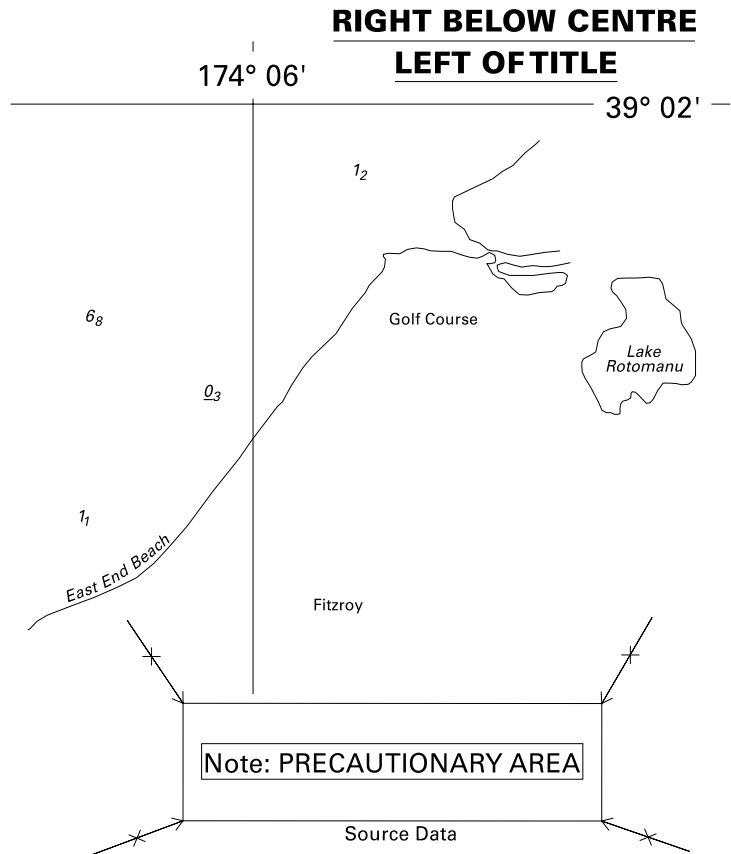

<i>Issued as a guide to chart correction.</i>		<i>Use in conjunction with the appropriate NZ Notice to Mariners.</i>	
<b>LAST CORRECTION</b>	<b>NZ NTM No.</b>	<b>CHART No.</b>	
<b>NZ 143/03</b>	<b>NZ 94/07</b>	<b>NZ 4432</b>	

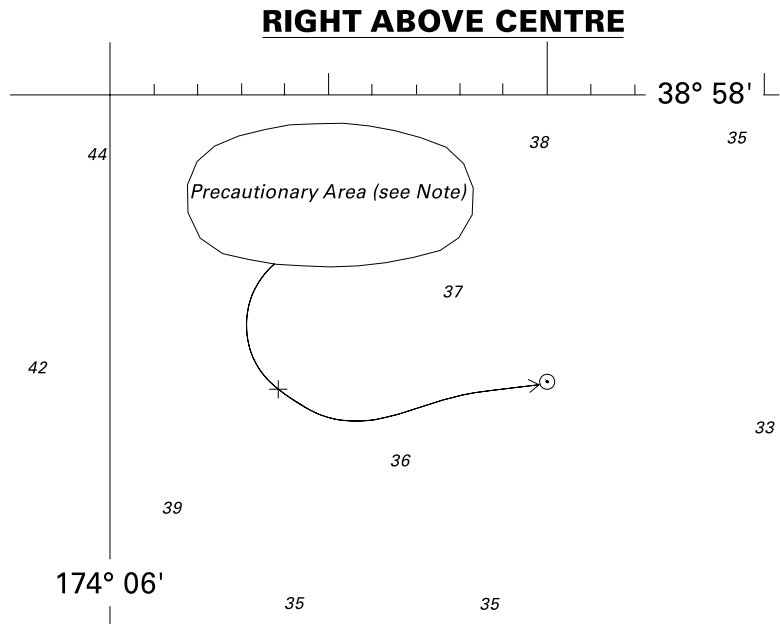
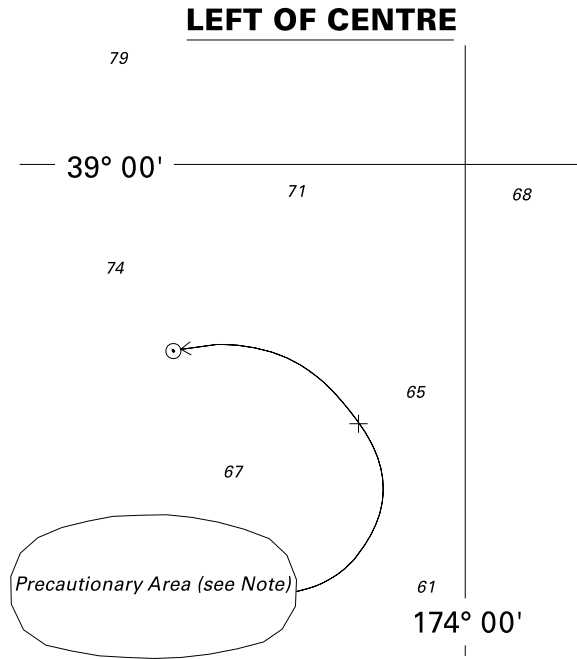

<i>Issued as a guide to chart correction.</i>		<i>Use in conjunction with the appropriate NZ Notice to Mariners.</i>	
<b>LAST CORRECTION</b>	<b>NZ NTM No.</b>	<b>CHART No.</b>	
<b>NZ 143/03</b>	<b>NZ 94/07</b>	<b>NZ 4432</b>	

Chart No. NZ 21 (INT 641)

PRECAUTIONARY AREA  
Entry into force date: 1 July 2007. All ships should navigate with particular caution in order to reduce the risk of a maritime casualty and resulting marine pollution in the precautionary area.

Chart No. NZ 23 (INT 640)

PRECAUTIONARY AREA  
Entry into force date: 1 July 2007. All ships should navigate with particular caution in order to reduce the risk of a maritime casualty and resulting marine pollution in the precautionary area.

Chart No. NZ 25 (INT 648)

PRECAUTIONARY AREA  
Entry into force date: 1 July 2007. All ships should navigate with particular caution in order to reduce the risk of a maritime casualty and resulting marine pollution in the precautionary area.

Chart No. NZ 43

PRECAUTIONARY AREA  
Entry into force date: 1 July 2007. All ships should navigate with particular caution in order to reduce the risk of a maritime casualty and resulting marine pollution in the precautionary area.

Chart No. NZ 45

PRECAUTIONARY AREA  
Entry into force date: 1 July 2007. All ships should navigate with particular caution in order to reduce the risk of a maritime casualty and resulting marine pollution in the precautionary area.

Chart No. NZ 48

PRECAUTIONARY AREA  
Entry into force date: 1 July 2007. All ships should navigate with particular caution in order to reduce the risk of a maritime casualty and resulting marine pollution in the precautionary area.



Chart No. NZ 443

PRECAUTIONARY AREA  
Entry into force date: 1 July 2007. All ships should navigate with particular caution in order to reduce the risk of a maritime casualty and resulting marine pollution in the precautionary area.

Chart No. NZ 4432

PRECAUTIONARY AREA  
Entry into force date: 1 July 2007. All ships should navigate with particular caution in order to reduce the risk of a maritime casualty and resulting marine pollution in the area covered by this chart.